

TOP VIEW

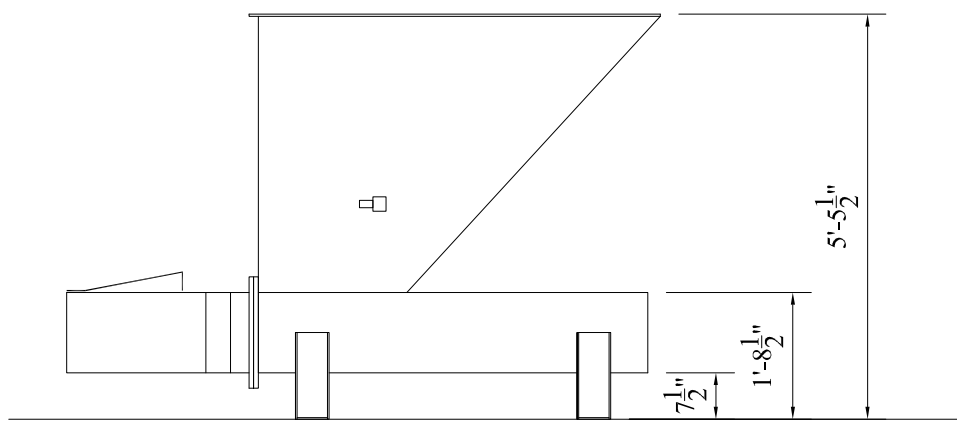

LEFT VIEW

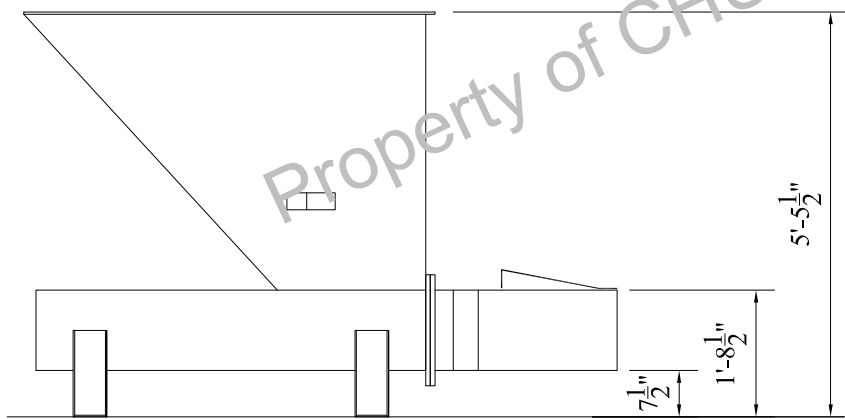

RIGHT VIEW

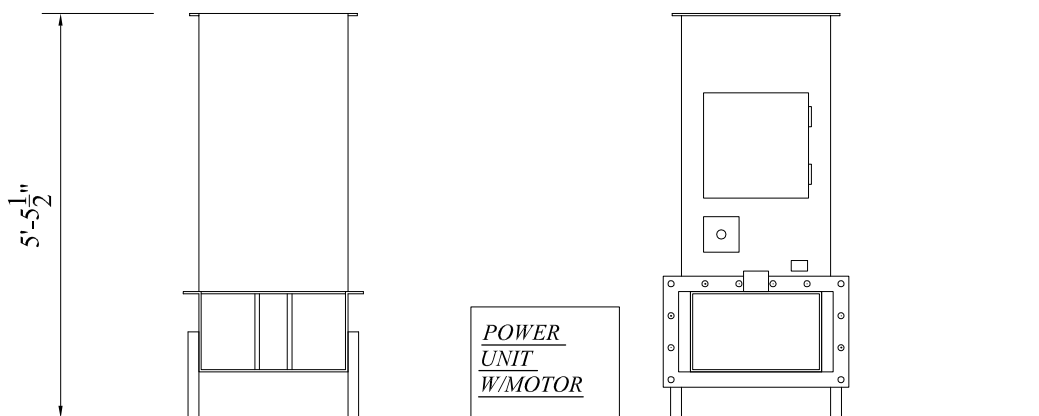

BACK VIEW

FRONT VIEW

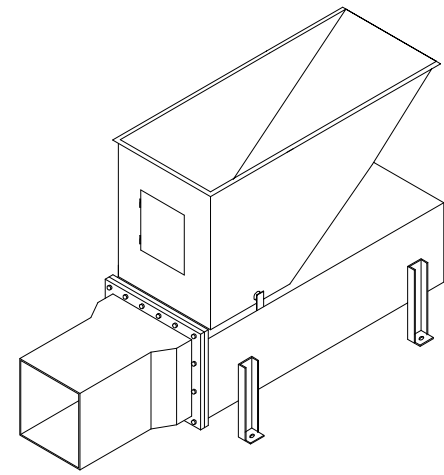

NOTE:

THIS DRAWING IS THE PROPERTY OF CHUTES INTERNATIONAL MANUFACTURING AND IS LOANED ON THE CONDITION THAT IT IS NOT TO BE REPRODUCED AND IS NOT TO BE USED IN WHOLE OR PART TO FURNISH INFORMATION FOR THE MAKING OF DRAWINGS OR COMPACTOR.

1	WEIGHT : 1700 LBS CYCLE TIME : 36 SECONDS APPROX.
2	<u>STRUCTURE</u> BOTTOM OF COMPACTOR: 3/8" + 1/4" WEAR PLATE FRONT OF RAM: 3/8" C.R. STEEL FLOOR OF RAM: 1/4" + 1/4" WEAR PLATE
3	HOPPER SIDES & FRONT TO BE FABRICATED OF 11 GA. COLD ROLLED STEEL WITH 1/4" IMPACT PLATE.
4	"BAG FULL" LIMIT SWITCH, PHOTO EYE FOR AUTOMATIC CYCLING.
5	4" DIA. X 2 1/4" X 27" STROKE CYLINDER 1350 P.S.I. NORMAL PRESSURE 2900 MAX. P.S.I. PRESSURE 3.65 G.P.M. PUMP 7.5 HP MOTOR 12 GALLON HYDRAULIC OIL TANK "UL" LISTED CONTROL PANEL ON/OFF KEY SWITCH
6	FRONT SIDE ACCESS DOOR WITH SAFETY INTERLOCK SWITCH.
7	POWER: 208V, 3 PHASE, STANDARD .
8	RAM RETRACT PUSH BUTTON ON FRONT OF HOPPER.
9	DISCONNECT BOX TO BE LOCATED WITHIN 5' OF CHUTE DISCHARGE. 3-PHASE (3 HOT-WIRES) + NEUTRAL AND GROUND FOR A TOTAL OF 5 WIRES. REQUIRES 30 AMP BREAKER WITH DEDICATED CIRCUIT (ALL PROVIDED BY OTHERS).

OPTIONAL ADDS

POWER

480V, 3 PHASE

1ST SUBMITTAL		
RESUBMITTAL		
APPROVED FOR FAB.		

Job Name:	
Customer:	
City:	
State:	
Item:	DURABAGGER DB-100
PO No.	JOB No.

CHUTES
INTERNATIONAL
MANUFACTURING
© 2012 CHUTES International

Phone: (301) 753-4100
Toll Free: 800-88-CHUTE
Fax: (301) 753-4109
4400 Austin Lane
White Plains, MD 20695
WWW.CHUTES.COM