

4

3

2

1

B

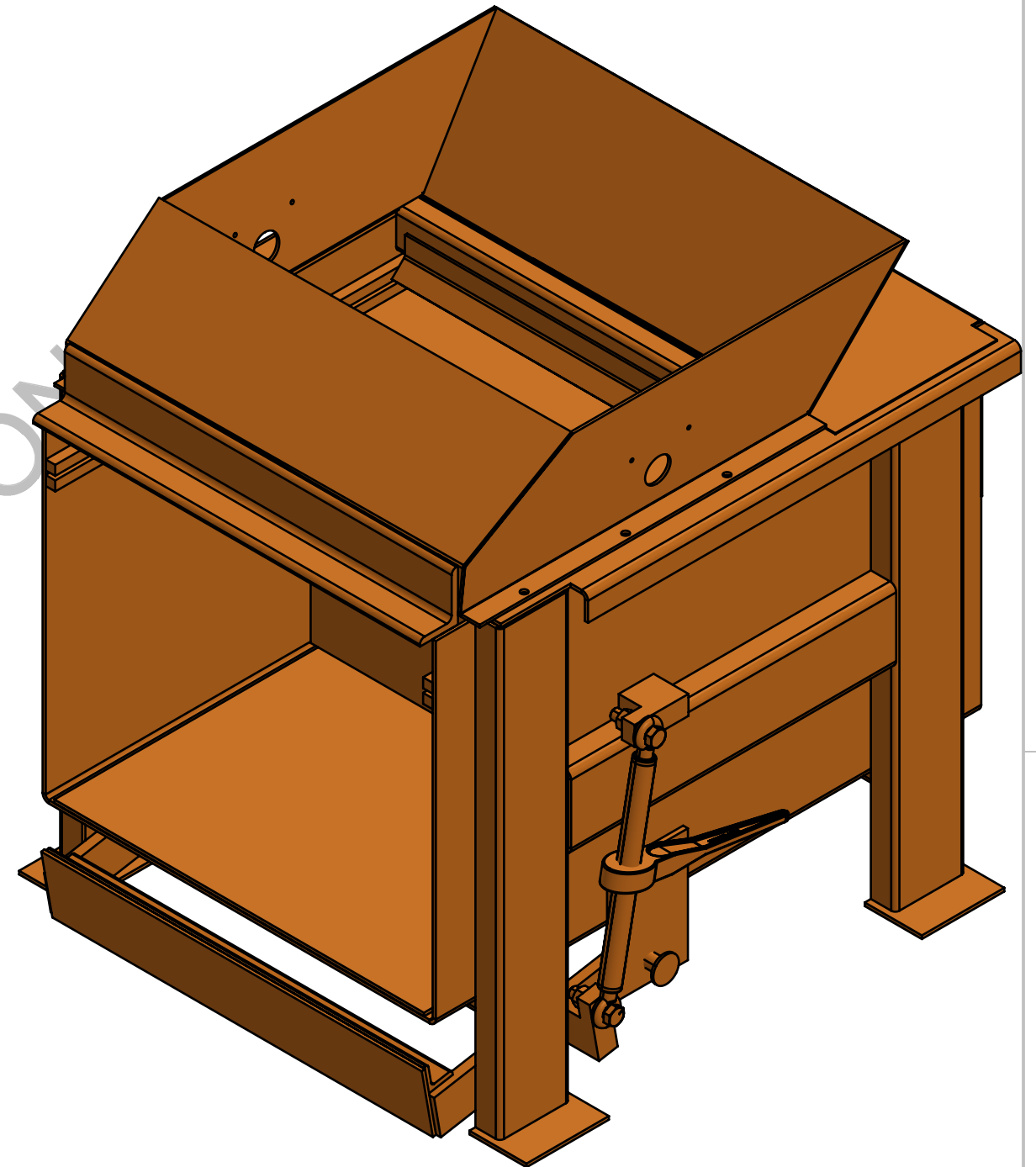
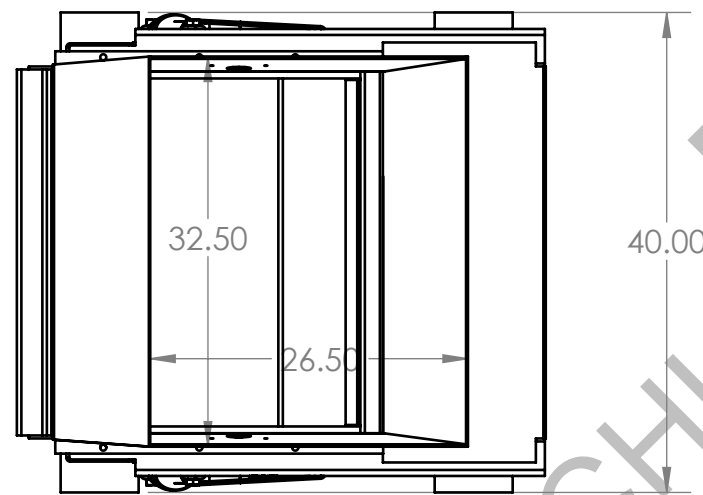
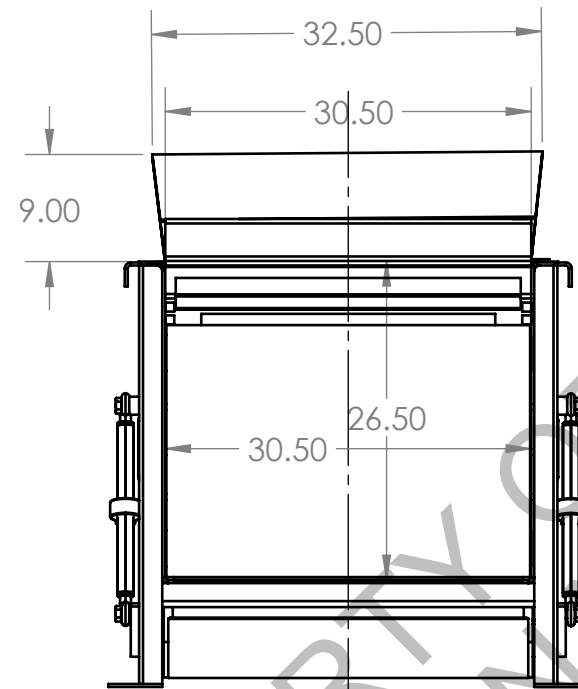
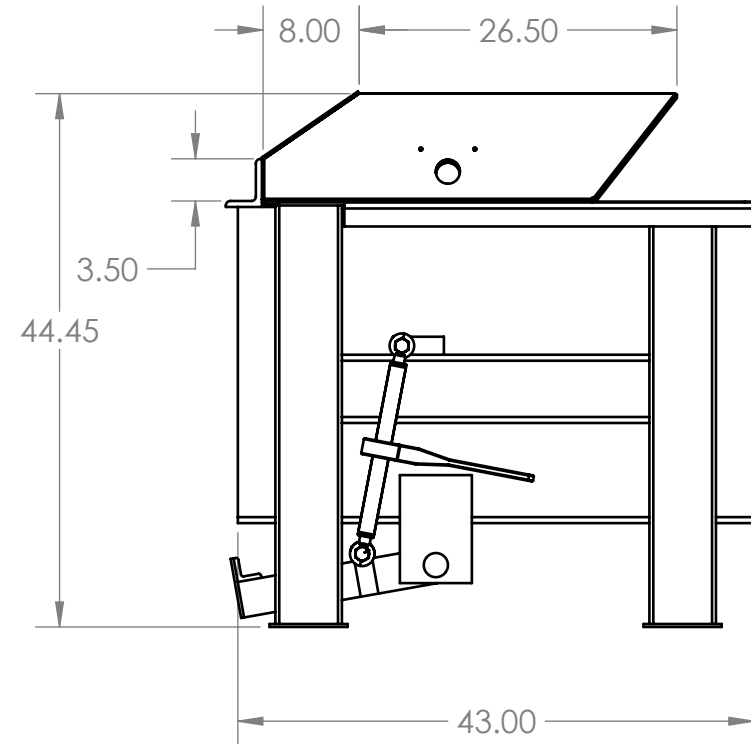

B

A

A

UNLESS OTHERWISE SPECIFIED: DIMENSIONS ARE IN INCHES TOLERANCES: FRACTIONAL ± 1/16 ANGULAR: MACH ± 1° BEND ± 1° BEND-LINE PLACEMENT ± 0.010 THREE PLACE DECIMAL ± 0.100 WELD THICKNESS + 1/16 SHEET METAL SPECIFICATIONS COMMENTS:	NAME	DATE	<b>CHUTES</b> <small>PATENTED CHUTES INTERNATIONAL™</small> <b>DESCRIPTION:</b> <h2>DP500HD Short Body</h2> SIZE <b>B</b> PART ID: <b>Compactor</b> REV <small>DO NOT SCALE DRAWING</small> SCALE: 1:16 SHEET 1 OF 1
	DRAWN	KASSIE 07/18/24	
	CHECKED	ENG'G	
	MFG APPR.	MFG'G	
PROPRIETARY AND CONFIDENTIAL THE INFORMATION CONTAINED IN THIS DRAWING IS THE SOLE PROPERTY OF CHUTES INTERNATIONAL MANUFACTURING. ANY REPRODUCTION IN PART OR AS A WHOLE WITHOUT THE WRITTEN PERMISSION OF CHUTES INTERNATIONAL MANUFACTURING IS PROHIBITED.			33 Industrial Park Dr. Waldorf, MD 20602 Phone: (240) 448-5000 Fax: (301) 753-4108 WWW.CHUTES.COM

4

3

2

1