

4

3

2

1

## Standard Side Hinge Door Dimensions

Nominal Door Size	Hinge Location	Door ID #	Frame Sleeve		Frame Flange		Outside Trim	
			A*	B	C	D	E	F
15" x 15"	Left Side	1515LSH	15 1/2"	15"	17 7/8"	21 3/4"	21 5/8"	21 "
	Right Side	1515RSH						
18" x 18"	Left Side	1818LSH	18 1/2"	18"	20 7/8"	20 3/4"	24 3/4"	24 "
	Right Side	1818RSH						
21" x 21"	Left Side	2121LSH	21 1/2"	21"	23 7/8"	23 3/4"	27 7/8"	27 "
	Right Side	2121RSH						
24" x 24" **	Left Side	2424LSH	24 1/2"	24"	26 7/8"	26 3/4"	30 3/8"	30 1/8"
	Right Side	2424RSH						

\*Dimension A Includes Tolerance for Top Plunger, Hinge Screws and Hex Nuts (Screws and Hex Nuts Not Shown in Drawing).

\*\* Does not meet 5lbs ADA pull test

## Important Notes:

- The through-wall rough opening/throat dimensions should be 1/4" larger than the Frame sleeve dimensions (A and B).
- All Doors are noiseless, self-closing, self-latching, and supplied with an ADA compliant locking lever handle and two keys.
- With the exception of the frames, all standard doors are made from 430 ROF Stainless Steel material.
- All Doors are UL Labeled:
  - Rated: 1 1/2 hour
  - Temperature rise less than 250°F in 30 minutes

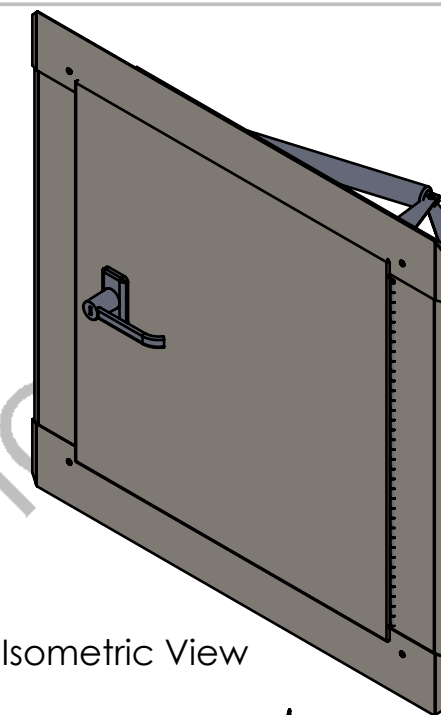
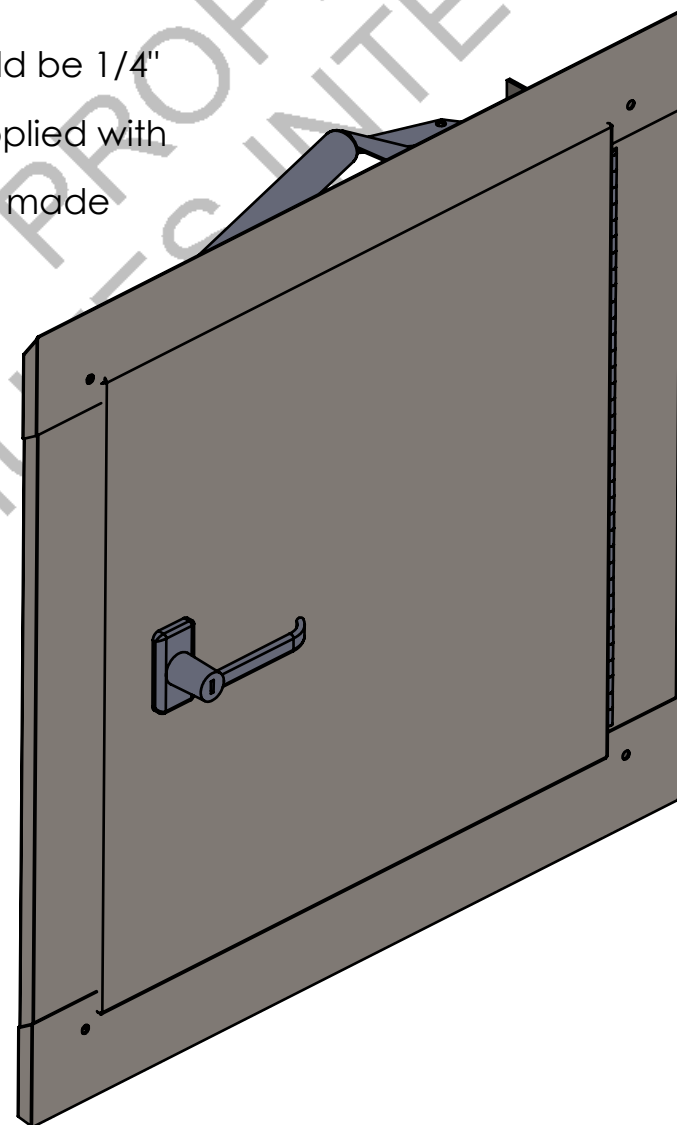

Isometric View

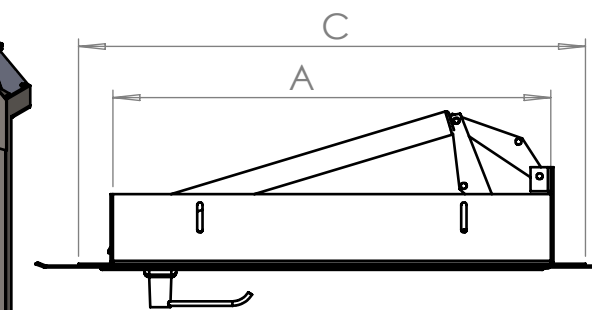

Top View

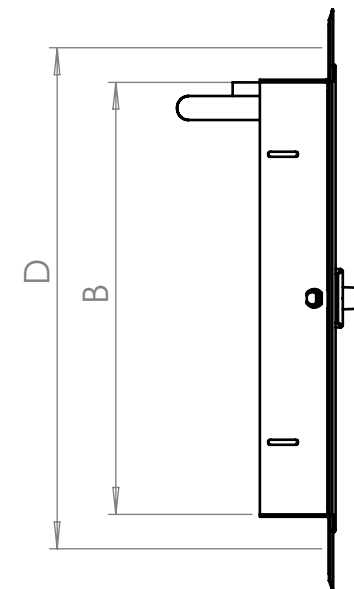

Side View

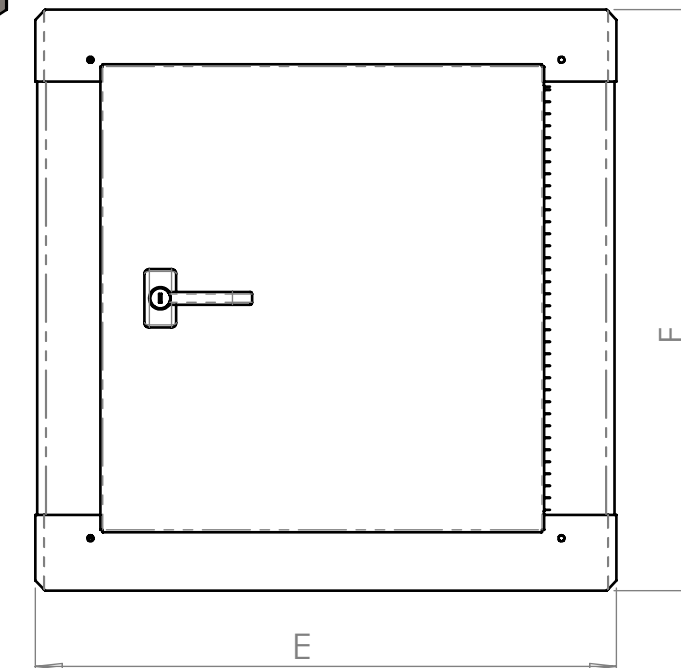

Front View

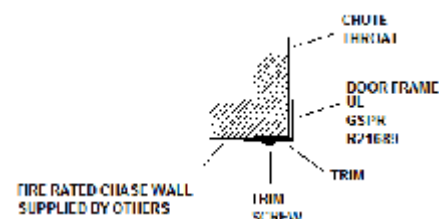

UNLESS OTHERWISE SPECIFIED:

DIMENSIONS ARE IN INCHES

TOLERANCES:

FRACTIONAL  $\pm 1/8$   
 ANGULAR: MACH  $\pm 1^\circ$  BEND  $\pm 1^\circ$   
 BEND-LINE PLACEMENT  $\pm 0.010$   
 THREE PLACE DECIMAL  $\pm 0.125$   
 WELD THICKNESS  $+ 1/16$

SHEET MATERIAL:

Various

COMMENTS:

Door Panel and Trims are 430  
ROF Stainless Steel

Frame is Mild Steel with a  
Enamel Painted Finish

NAME

DRAWN KASSIE

CHECKED

MFG APPR.

DATE

07/19/22

PROPRIETARY AND CONFIDENTIAL

THE INFORMATION CONTAINED IN THIS  
DRAWING IS THE SOLE PROPERTY OF CHUTES  
INTERNATIONAL MANUFACTURING. ANY  
REPRODUCTION IN PART OR AS A WHOLE  
WITHOUT THE WRITTEN PERMISSION OF  
CHUTES INTERNATIONAL MANUFACTURING  
IS PROHIBITED.

**CHUTES**  
PATENTED  
CHUTES INTERNATIONAL™

33 Industrial Park Dr.  
Waldorf, MD 20602  
Phone: (240) 448-5000  
Fax: (301) 753-4108  
WWW.CHUTES.COM

DESCRIPTION:

Typical Standard  
Side Hinge Doors

SIZE  
**B**

PART ID:  
Standard Side Hinge Doors

REV  
**C**

DO NOT SCALE DRAWING

SCALE: 1:10

SHEET 1 OF 1

4

3

2

1

B

A