

INTRODUCING CHUTES INTERNATIONAL BIN BUTLER

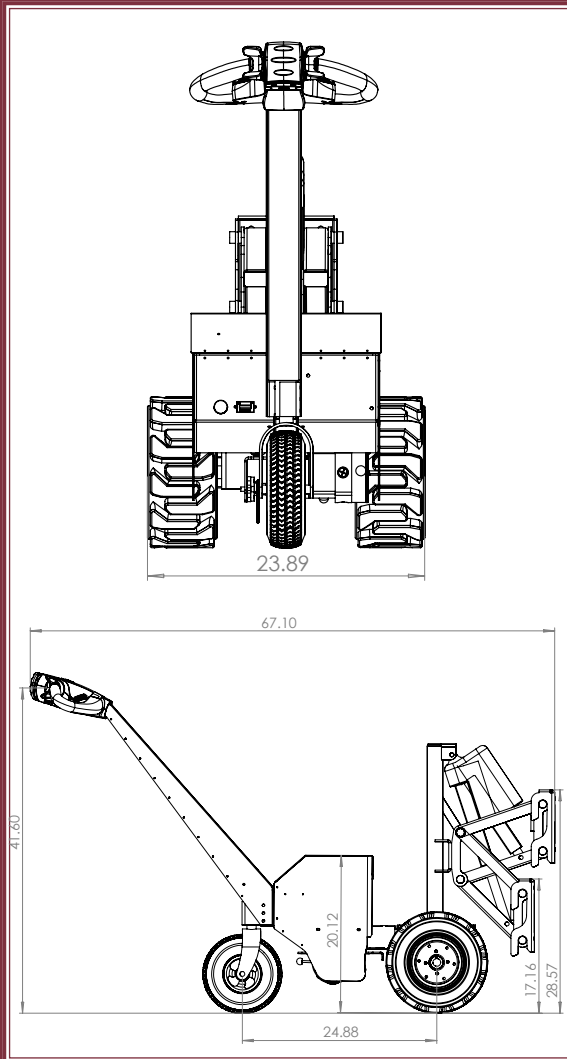

COMPACT DESIGN 6' X 2' X 3'



Standard Features:

- Tow capacity of up to 8,000 pounds/3628 kilograms.
- Tackles grades up to 8 percent when towing.
- Speed max velocity 222 feet per minute.
- Easy connect system
- Maintenance-free 36v - 3 battery system.
- Chargers work with 120 volt standard electric outlets.
- Power lift option offers greater traction.
- Compact design allowing for easy storage.

BIN BUTLER
by CHUTES International

CHUTES
PATENTED
CHUTES INTERNATIONAL™

33 Industrial Park Drive, Waldorf, MD 20602
(800) 88-CHUTE | (240) 448-5000 | WWW.CHUTES.COM

QUICK START GUIDE

CHUTES Dumpster Dolly is designed to tackle the toughest hauling jobs with ease. Engineered to accommodate a wide range of wheeled dumpsters—regardless of size or weight—this heavy-duty towing dolly ensures effortless maneuverability across job sites, warehouses, and commercial properties.

Use the up/down button to engage the EZ connect bracket.

On/Off Button

Variable speed throttle allows users to operate forward and reverse at their own pace.
Forward - lift the orange lever up.
Reverse - press the orange lever down.

Quick stop button for added safety.

Maintenance-free 36-volt three-battery system. Chargers for the system work with 120-volt standard electrical outlets.

Quick connect charging port. Battery level indicator. Green = charged.

Engineered with a power lift option to offer greater traction.

COMPACT DESIGN
6' X 2' X 3'

EZ connect bracket for simple and swift connections.

Upgraded tires power through all terrain and tackle grades of up to 8% when towing. Tow capacity of up to 8,000 pounds.