



# TRASH, LINEN & RECYCLING CHUTE INSTALLATION MANUAL

(INCLUDING OPERATION & MAINTENANCE MANUAL)



**CHUTES International Manufacturing**

33 Industrial Park Drive  
Waldorf, MD 20602

**1-800-882-4883**

[www.chutes.com](http://www.chutes.com)

[info@chutes.com](mailto:info@chutes.com)

## Gravity Flow Trash, Linen & Recycling Chutes Operation and Maintenance Manual

CHUTES International's Trash, Linen and Recycling Chutes are designed to provide a clean and efficient method of removing waste and soiled linens from upper floors to a centrally located discharge area on a lower floor.

These chutes are available in a standard 16 gauge (minimum) aluminized or stainless steel: aluminized steel is the preferred steel, as it is economical and durable. Other gauge and material options available.

Chutes are available in various diameters, however, the NFPA (National Fire Protection Agency) requires a minimum diameter of 24 inches.

Normally, there are two sections of chute for each floor; one straight section (a 'B' section) and one section with built-in intake throat and door. Unusually high floors might have extra sections or different configurations depending on the specific jobsite conditions.

Each chute comes with a full diameter vent of same gauge as chute, discharge outlet, sprinkler system, flushing spray head, and various optional accessories, upon request.

### **INTAKE DOORS**

There are several types of intake doors; bottom or side hinged (hydraulic or pneumatic) with or without interlock. The standard 15" X 18" bottom hinged, hopper style door is recommended for typical trash chutes. When opened, the bottom-hinged door allows for easy disposal of waste into the chute, while eliminating unnecessary spillage and overflow of litter on to the floor.



Where specified, push-button operated handicap accessible (pneumatic bottom hinged), hopper style doors; for typical trash chutes are available. This option provides easy disposal of waste into the chute eliminating the need to manually open the door for waste disposal.



Interlock features allow for safe operation of the chute system by locking out all remaining intake doors when one door is in operation, protecting persons using the trash disposal system from falling debris from intakes above. (See Accessories Section on page 4).

The side hinged door, typically recommended for linen chutes, provides a greater accessible area to deposit bundles of soiled linen.

Both bottom hinged doors and side hinged doors are self-closing, noiseless and self-latching. Both type doors are UL classified, a chute frame and door assembly with a 1½ hour fire rating and a temperature



rise of 250° F maximum in 30 minutes. (See appendix A)

## **VENT**

The purpose of a vent is to dissipate odors, as well as to dissipate hot gases in the event of a fire within the chute.

NFPA codes require a full diameter vent, penetrating and extending 3' above the roof. CHUTES International's full diameter vent comes complete with roof flashing, riser and metal safety cap and is of 12 gauge aluminum to better resist the external elements.



## **DISCHARGE**

There are three types of discharge outlets:

### **Accordion Type Damper Discharge:**

The accordion discharge is recommended for use on trash chutes. The discharge is a UL labeled fire damper, held open by a 165°F fusible link and equipped with tension coils on either side of the damper to permit closing if the link breaks. Monthly inspections of the discharge should be made to ensure that the links are intact and that no waste has collected in the horizontal tracks, which might interfere with its closing path.

***NOTE: Once door has been used it MUST be replaced.***

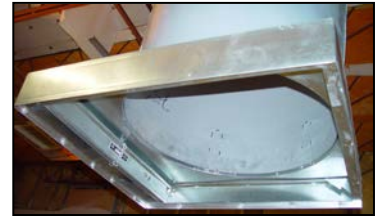

**Rolling Incline Type Discharge:** The discharge door of UL construction, is held open by a 165°F fusible link. The door will roll shut if the link is melted. Monthly inspections of the discharge should be made to ensure that the link is intact and that no waste has collected in the horizontal tracks of the discharge, which might interfere with its closing path.



**Hopper Type Discharge:** The hopper type discharge is UL labeled and typically used on linen chutes. The discharge is top hinged and held open by chains with a 165°F fusible link. The hopper type discharge can also extend into the discharge room from the ceiling and is supported on a pedestal(s). The hopper discharge should be kept clean and free of damage caused from service impact and shall remain open at all times. It is not intended to be used as a 'shut off' door when carts are changed, etc. See 'General Notes' on page 6.



## **SPRINKLER SYSTEMS**

One automatic sprinkler head (required by NFPA code) is furnished as standard equipment at the top of all chutes. On rubbish chutes in particular, additional sprinkler heads should be furnished at intermediate and lower levels.



A sprinkler at the top intake, at alternate floor levels and the bottom intake for linen, trash and recycling chutes, are required. These heads are normally installed in the top corner of the intake throat to protect them from falling material and are hidden behind a shield to prevent water from spraying out of the intake door and to prevent material that is charged into the throat from contacting the head.

These automatic sprinkler heads fuse at 165° F to open up and flood the chute. When the fire is out, the fused heads must be replaced. The automatic sprinkler heads furnished with the chute should be piped in accordance with NFPA standards.

## **FLUSHING SPRAY HEAD**

Most chutes are flushed periodically to keep them clean. A flushing spray head is furnished at the top of each chute as standard equipment. When supplied with water (hook-up by others), the head radiates a flow of water to the inner chute wall. The water will tend to channel when first started, but will spread out as cleaning occurs. How often and how long the chute should be flushed depends upon many variables such as chute usage, size, condition, water temperature and pressure.



## **ACCESSORIES**

### **DISINFECTING AND SANITIZING UNIT (D&S UNIT)**

A disinfecting and sanitizing unit is sometimes requested for trash, linen and/or recycling chutes to control odor and bacteria (hook-up by others). The unit is comprised of a reservoir tank and proportioning valve which is located above the top intake of a chute. It injects a disinfecting solution into the water flow from the flushing spray head system.



### **ACCESS DOOR**

The Access Door (installed by others), located above the top intake of the chute, allows access to the valves that operate the flushing spray head and/or sanitizing unit. The access door is 15" X 15", side hinged, constructed of stainless steel, and is classified for a UL 1½ hour fire rating and a maximum temperature rise of 250° F 30 minute label.

### **ELECTRIC INTERLOCKS**

Electric Interlock doors are designed to lock out all other intake doors on a chute when one door is opened. When chute is in use, all other chute doors will remain locked with a light showing another door is in use. Maintenance personnel, by means of a key

switch at the power supply control box, have the ability to lock out the intake doors when servicing the equipment. This will close all doors when the discharge container is out of position or while maintenance is being performed in the discharge area.

Electrical Interlock system comes standard with service switch which will disable the interlock feature.

The interlock system is pre-wired and is designed to be plugged into a 120V receptacle and stepped down to 24VDC located in the power supply box. (120V receptacle supplied by others).

### **PNEUMATIC DOORS (STANDARD & INTERLOCK)**

Pneumatic standard and interlock intake doors are designed for ease of operation. Pneumatic doors are controlled by a green push button, which will automatically open the intake door for 7-10 seconds to allow for the disposal of trash into the chute system.



The optional pneumatic interlock feature will function similar to the electric interlock. When the chute is in use; all other chute doors will remain locked and a red indicator light on the top panel will signify chute in use. This will allow for the safe operation of the chute system by protecting persons from falling debris from above.

Pneumatic doors are powered by an air compressor, regulator and dump valve, located in the discharge area. The pneumatic doors can be locked out for routine maintenance by manually turning off the dump valve to release all air from the system. The Pneumatic system is pre-wired with 1/8" supply hoses and is designed to be plugged into an oil-free air compressor (120V receptacle source for air compressor supplied by others). The regulator is recommended to be set between 90-100PSI for continuous operation.

### **HEAT DETECTION SENSOR**

The heat sensor option can be installed on both electric and pneumatic interlock systems. This safety feature will shut the chute system down in the event of a fire emergency. The heat sensor on the electrical interlock will shut down the power source at the control box, which will prohibit intake doors from being opened.

The heat sensor on the pneumatic interlock will automatically dump all air from the chute system disabling chute intake door operation.

### **GENERAL NOTES**

Linen and many types of rubbish are highly combustible. It is against NFPA code to store trash or linen in the chute. The discharge MUST remain open at all times and be equipped with a device that will automatically close the chute in the event of a fire in the collection room. The collection room must have a hose or hand fire extinguisher, as

well as an automatic sprinkler system (supplied by others). Please refer to installation instructions prior to installing or operating any chute system.

## **MAINTENANCE**

The only maintenance required for the intake doors is to keep them clean and free from structural damage that may be caused by misuse, carelessness, or vandalism and to clean and lubricate door hinges and plungers. Pneumatic doors should never be wedged in the open position, this will cause the door to malfunction and operate improperly. Annual chute washings for chutes are strongly recommended.

## **COMPRESSOR** – *For Pneumatic Systems ONLY*

### **Draining the air tank**

The frequency at which you should drain the air tank depends on the environmental conditions and the amount of operating time logged. The average draining frequency is every 2-3 days.

1. Place the air compressor above a container capable of holding water.
2. With compressed air in the air tank, slowly turn the the drain valve knob to the forward (open) or straight position. The water will drain out.
3. After all of the accumulated water has drained out, turn the drain valve knob to the closed or left position in order to avoid leakage.
4. Draining the air tank protects parts from rust and corrosion.
5. Keep track of maintenance performed.

### **Cleaning or changing the air filter**

The air filter is designed to reduce noise and help prevent particulates in the air from entering and damaging the air compressor.

After being used for a period of time, the air filter will become clogged. This will reduce the air intake capabilities of the air compressor, reducing performance. Therefore, the air filter must be cleaned or replaced regularly.

1. Open the lid on the air filter, then remove the air filter element.
2. To clean the element blow off or brush off the dirt and dust.
3. If clogged, replace with a new filter.
4. Keep track of maintenance performed.

### **Testing for leaks**

Make sure all connections are tight, do not overtighten.

A small leak in any hose or pipe connection will reduce the air compressor's performance.

To test for small leaks, spray a small amount of soapy water on the area suspect of leaking. If the soap bubbles, replace the broken part.

### **Cleaning**

Clean items with a soft brush, or wipe with a moistened cloth using a biodegradable solvent. Do not use flammable liquids such as gasoline or alcohol. Always keep parts clean from dirt and dust for better performance.

# Typical Trash Chute Elevation Drawing

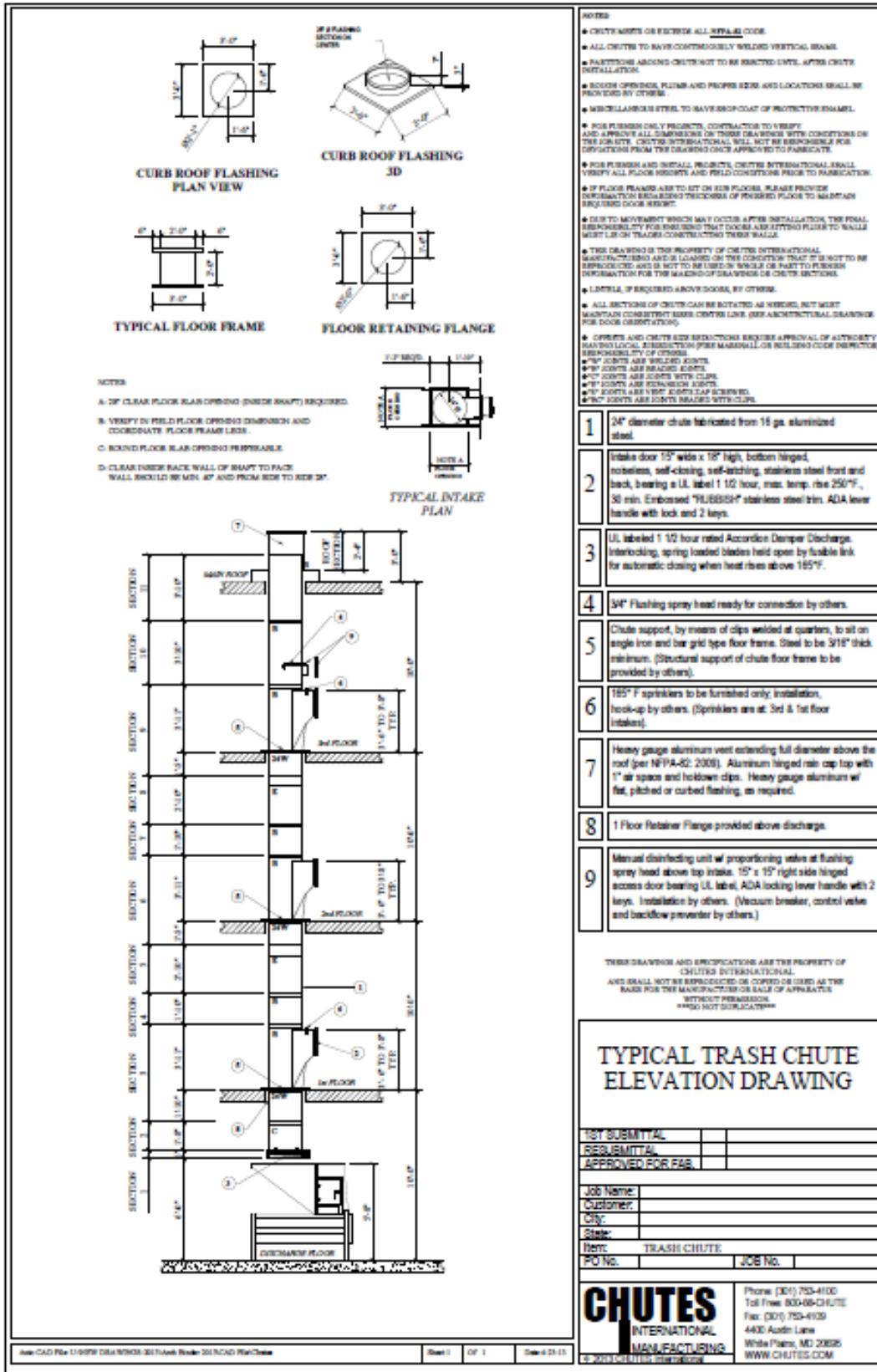

# Typical Linen Chute Elevation Drawing

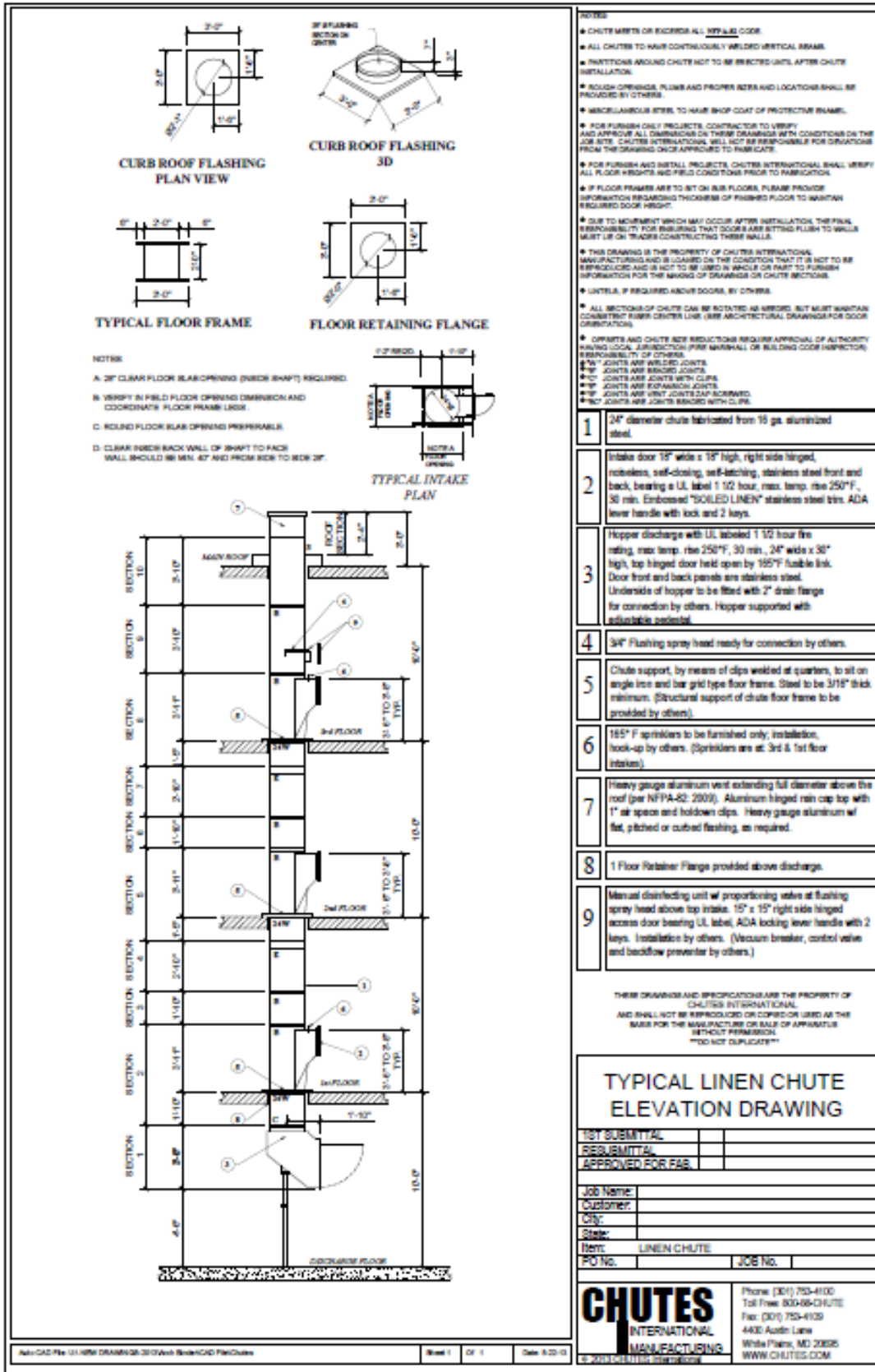



# INSTALLATION INSTRUCTIONS FOR TRASH, LINEN & RECYCLING CHUTES

## PRE-INSTALLATION

- Before start of job, make sure that the installation crew foreman reviews and understands the chute shop drawings.
- Confirm that the slab penetrations are properly sized (chute diameter plus 4") and that all openings are aligned plumb per the detailed shop drawing and are clear of obstructions. Also, confirm that floor heights and other applicable dimensions are in accordance with the approved shop drawings.
- Upon receipt of chute, examine all goods carefully and match the individual pieces to the shop drawing and shipping memo, confirming job dimensions and quantities. *PLEASE NOTE: You have 24 hours, after receipt of order, to report any problems to CHUTES International, so be sure to thoroughly check all orders immediately upon receipt.*
- Only a few simple tools are required to install CHUTES International Trash, Recycling and Linen Chutes:
  - Hammer (recommend rubber mallet)
  - 2 Flat Head Screw Drivers
  - Cordless Drill with 5/16" Hex Head Bit
  - Hammer Drill/Anchor Pins
  - Wrench Ratchet Set (for Discharge)
  - Measuring Tape
  - Level
  - Ladder
  - Self-Tapping Sheet Metal Screws
  - All Required Safety PPE
- All materials are prefabricated to dimensions shown on the shop drawings. No field cutting or fitting is required. The joints are 'slip jointed' to permit slight variations in height.
- Fully assembled door and frame are mounted into the chute intake throat with sheet metal screws. Installation may be in masonry or drywall type walls. Door closer tensions are pre-adjusted. Stainless steel protective covering should not be removed until after plastering and painting are completed. Trim is packed separately (in the same shipment but not yet installed on door frame). At contractor's discretion, trim could be installed at time of chute installation or after completion of face wall.
- All doors and trim pieces are identified with floor numbers for each of installation.

## INSTALLATION OF CHUTE SECTIONS

- Distribute chute sections to the appropriate floors. All sections are numbered and should agree with the as-built shop drawing.
- Start installation at the first floor above discharge level.
- Center floor frame over slab opening. If isolator pads are specified, install them onto floor frames prior to placement.

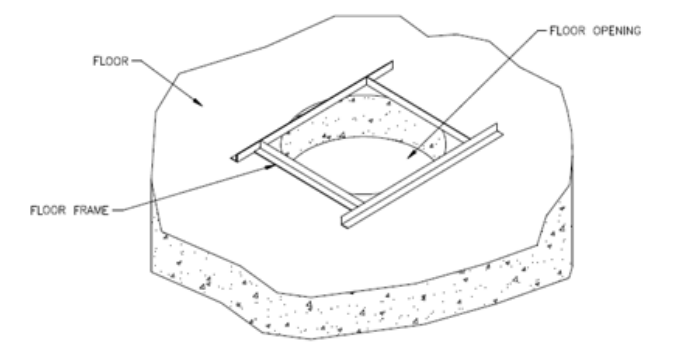

- Lower intake section down through floor frame and slab opening. Ensure that all four (4) clips are properly engaged on floor frame.

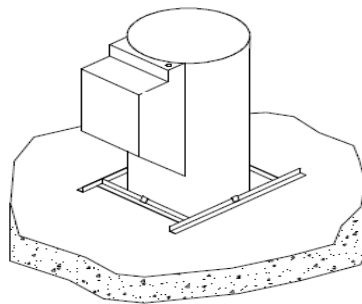

- Insert beaded section into intake section, using flat head screw driver to guide section, if needed. Ensure that bead is firmly seated against top of intake section.
- Proceed up to next floor above and repeat the same 4 steps, inserting the bottom of the next intake section into the top of the beaded section below.
- Repeat the above steps until the top most intake section is installed.



- Install the wash down section, if required, by inserting the beaded end into the top of the last intake section, keeping the 'wash down unit' to the front of the chute, in line with the intake doors.
- Add beaded vent sections, bead down, to the top of the wash down section, until vent riser penetrates top of roof slab. Vent sections **only** (those sections above the last top intake) may be screwed together at joints with self-tapping sheet metal screws.



Also, inspect sprinklers and wash down unit to ensure they are ready for connection by others. The automatic sprinkler heads, furnished with the chute, should be installed and piped (by others) in accordance with NFPA standards.

### **INSTALLATION OF ROOF SECTION & FLASHING**

- Install roof flashing over vent section protruding through roof slab and seat roof flashing firmly on roof: flat, pitched or curb (curb as built by others) per job site conditions.
- For curb flashing installation, always fasten through the vertical turndown (as shown).
- Roof flashing is to be attached and sealed to roof by others.
- Install roof riser section with vent cap over roof flashing, ensuring that bottom of roof section is firmly seated against bead of roof flashing. Secure roof section to roof flashing with 6 (six) self-tapping sheet metal screws. See Appendix B for roof vent and flashing configurations.

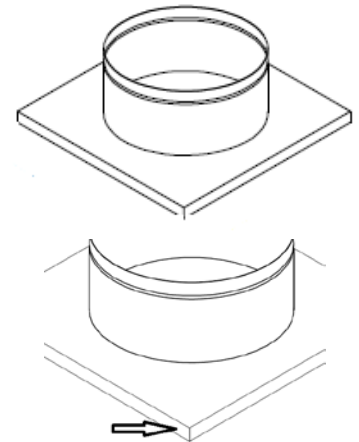

### **INSTALLATION OF CHUTE DISCHARGE**

- Ensure that the height of discharge door to finished floor level is per approved shop drawing to avoid subsequent problems with installation of carts or compactors.
- Align clips on discharge with clips on bottom of chute section in discharge room.



- Install the four (4) bolts, nuts & washers provided, level and square with adjacent walls, then tighten securely.

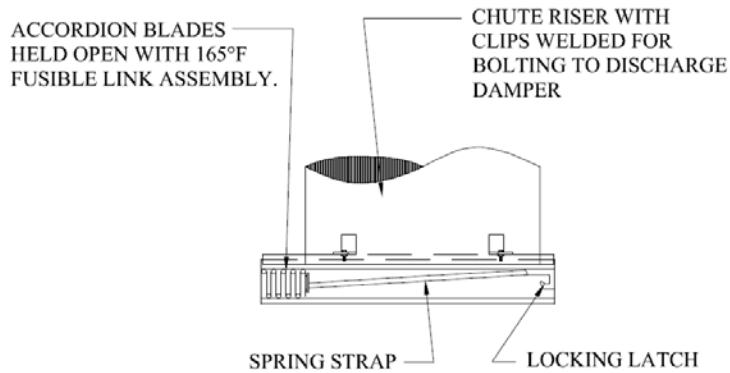

- Ensure that discharge is held open by the 165°F fusible link attachment.
- Install floor retainer flange to the ceiling of the discharge room, around the chute.
- Fire caulk the perimeter of the floor retainer flange around the chute and ceiling, if specified.



## INSTALLATION OF CHUTE INTAKE DOORS

- Ensure that the face of the intake door is square and plumb to the proposed face wall line (as provided by general contractor).
- Insert intake doors into chute intake and square face to intake. Secure door with zap screws in pre-punched slots. Re-measure to ensure face of door is flush with wall line (as provided by general contractor).
- Affix all stainless steel trim, 4 pcs. Provided separately (1 top trim, 1 bottom trim & 2 side trims) to intake doors. Leave protective stainless steel film on pieces until completion of drywall and painting (by others).
- After completing the installation, check all doors for correct operation and functionality; ensuring that all packing covering the intake doors is still intact to prevent damage to door during drywall construction.
- For linen hopper type discharge doors, installation is same as above, except that additional pedestal support should be bolted to bottom of discharge hopper, adjusted to hopper height and lagged to the floor. (See Appendix C)



## INSTALLATION OF OPTIONAL ACCESSORIES

### DISINFECTING & SANITIZING UNIT (D&S Unit)

- The D&S unit is to be connected to the flushing spray head by others.
- The disinfectant is regulated through a proportioning valve in conjunction with the siphoning action.
- The D&S Unit should be located above the top intake throat. The provided access door should be installed by others to allow access for maintenance and servicing of the unit. (See Appendix D)



### ELECTRIC INTERLOCKS

- Upon completion of chute section installation, install interlock equipped doors, in the same manner as standard intake doors, from top intake floor to bottom.
- Each interlock door will be supplied with a quick connect wiring harness connected to rear of door control box. Start at the top intake floor and carefully feed the wiring harness down the chute shaft, outside the chute and inside floor frames.
- Repeat steps for each intake, working from the top down to the discharge room.
- At each intake, attach wiring harness using supplied quick connect.
- The master power supply will be mounted in the discharge area in a desired location within 5' of chute discharge. Secure the wiring harness from the intake above the discharge room and make the proper connections via quick connect.

- Plug the power cord into a 120V receptacle. (Supplied by others). The system is now ready for operation.
- Test each door, starting at bottom and working up to top intake.
- Upon completion of successful test, install trim.
- Proper care should be exercised during the construction phase:
  - Ensure all doors are locked.
  - Ensure all wiring harnesses are protected from the masonry or drywall construction phase.
  - Ensure that the main wiring harness is protected until it has been permanently connected to the power supply box.
- Electrical interlock doors will not open unless energized. Interlock door trim must be removed and electric interlock cylinder raised manually, until electrical interlock system is functional, to open doors.
- Please contact CHUTES International with any technical questions related to the electrical interlock system @ 1-800-882-4883.

## **PNEUMATIC INTERLOCKS**

- Upon completion of chute section installation, install pneumatic equipped doors, in the same manner as standard intake doors from top intake floor to bottom.
- Each pneumatic door will be supplied with a tubing harness connected to rear of door control box. Start at the top intake floor and carefully feed the wiring harness down the chute shaft, outside the chute and inside floor frame.
- Quick connects located inside of each control box on top of door will allow tubing and cable to be connected to each door. (ie. 2<sup>nd</sup> floor door tubing and cable will drop down and connect to 1<sup>st</sup> floor door).
- Tubing harness attached to door one (1) will be routed to the discharge area and connected to the regulator & air compressor control box. This will energize the pneumatic system.
- Air compressor, regulator, shut off valve and control box will be located in the discharge area in a desired location within 5' of chute discharge. Shut off valve will enable all air to be manually dumped from the system for routine maintenance and service or in the event of an emergency.
- Once each pneumatic door has been connected, plug the air compressor into a 120V receptacle (supplied by others).

- Test each door, starting at bottom and working up to top intake.
- Upon completion of successful test, install trim.
- Proper care should be exercised during the construction phase:
  - Ensure all doors are locked.
  - Ensure all tubing harnesses are protected from the masonry or drywall construction phase.
  - Ensure that the main supply harness is protected until it has been permanently connected to the regulator and air compressor supply unit.
- Before preparing the pneumatic interlock system for normal operation:
  - Check that all quick connect wiring harnesses are securely attached.
  - Inspect and clean all components at each intake and before installing face plates.
  - Face plate labels (provided) to be installed per the attached layout in Appendix E by others after final clean-up. Remove protective door trim film.
- **AUTOMATIC DOOR - STAND CLEAR** Signage is recommended to be posted in disposal areas, to notify persons utilizing automatic doors, of moving parts (signs supplied by CHUTES will be included with O&M Manuals and can be found in Appendix F. Copies can be made and used as needed).
- Please contact CHUTES International with any technical questions related to the pneumatic interlock system @ 1-800-882-4883.

## HEAT DETECTION SYSTEM

- The electrical interlocking system will lock all intake doors and shut down system if the heat inside the trash room reaches a temperature of 165° F. The heating sensor device is to be located within 3' of the chute discharge.
- The pneumatic interlocking system will automatically dump all air from the chute system.
- Flex conduit and sensor holding box will be supplied and connected to the control box provided with each chute installation system. (Electrical or pneumatic options only).
- Smoke detection connection is provided in control box for hook-up by others.



## SOUND ISOLATION SYSTEM

- Floor frames are supplied with isolator pads, when specified.
- Factory applied sound dampening material.
- 3½” Foil-backed Batt wrap insulation.

## OPTIONAL FLOOR RETAINER FLANGES AT INDIVIDUAL FLOORS

- Mount to the underneath side of the floor slabs or ceilings to hold insulation (mineral fiberfill or fire-safing.)
- These floor retainer flanges should be secured to the floor slab/ceiling.



## RUBBER BAFFLES

- Installed at every intake to prevent backdraft when the door is opened.



Should you have any questions regarding the above procedures, please contact your chute dealer or CHUTES International directly at 1-800-88-CHUTE (1-800-882-4883).

**Many chute replacement parts are available online at [www.chutes.com](http://www.chutes.com) for your convenience.**

## Appendix A

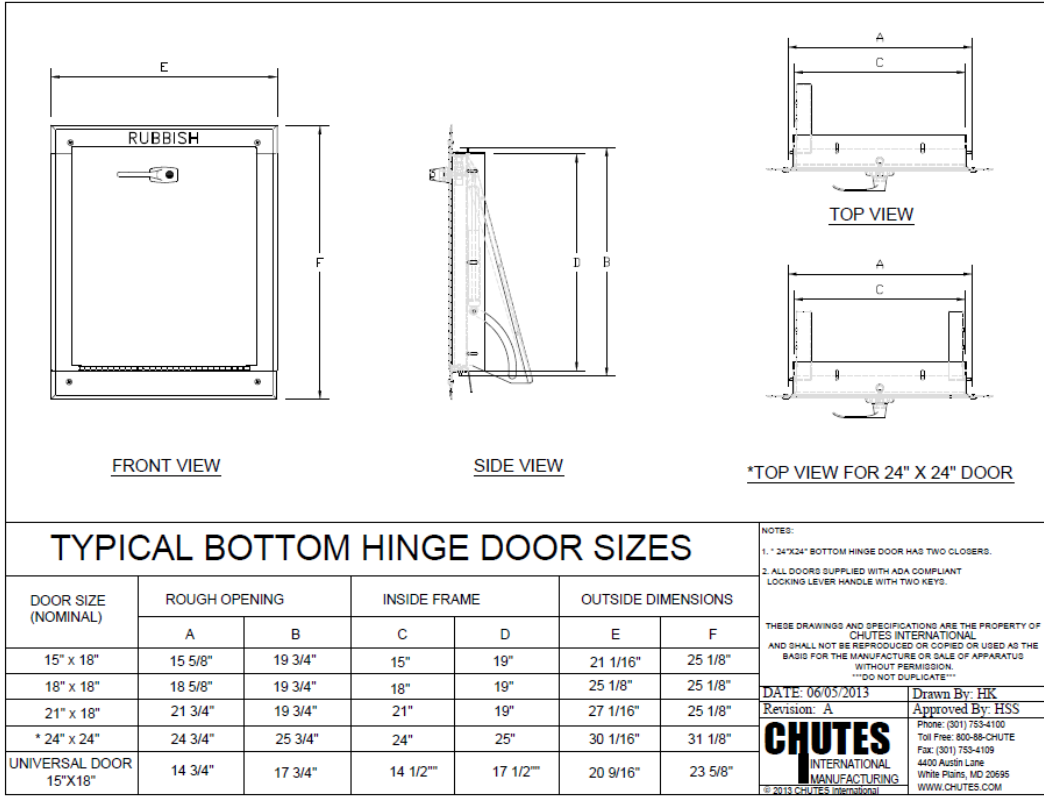

**Bottom Hinge Door – Typically Trash Chute Door (Above)**

**Pneumatic Bottom Hinge Door – Typically Trash Chute Door (Below)**

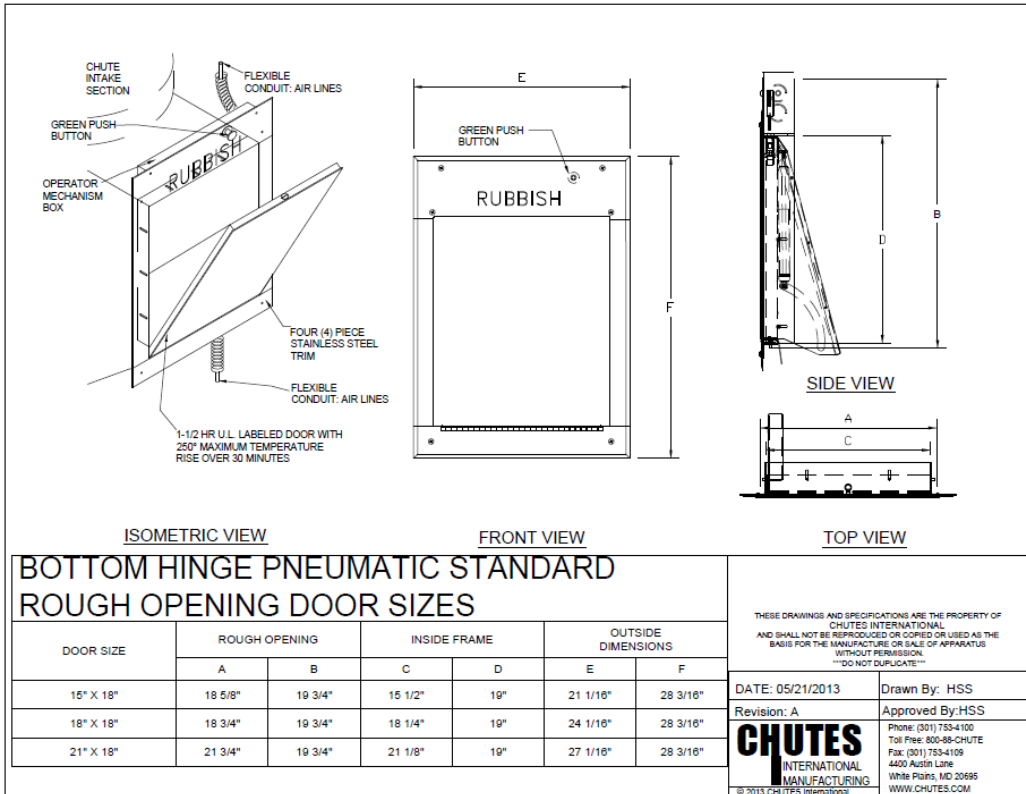

## Appendix A

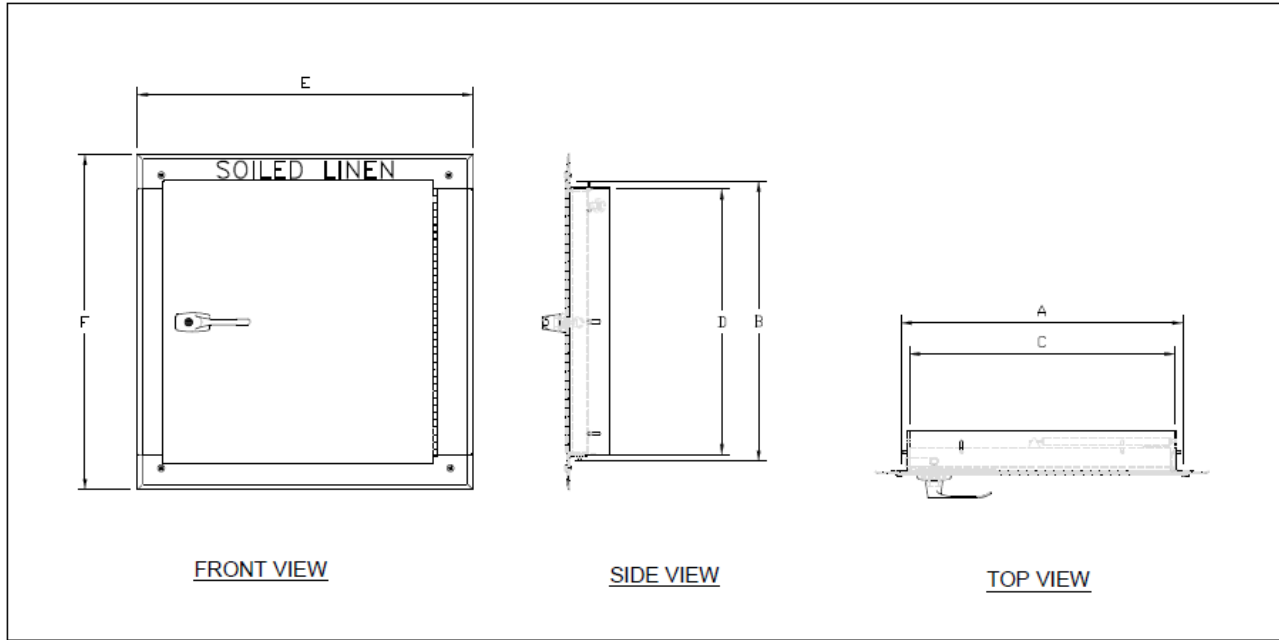

### TYPICAL SIDE HINGE DOOR SIZES

DOOR SIZE (NOMINAL)	ROUGH OPENING		INSIDE FRAME		OUTSIDE DIMENSIONS	
	A	B	C	D	E	F
15" x 15"	15 1/2"	15 1/2"	15"	15"	21 1/8"	21 1/8"
18" x 18"	18 3/4"	18 3/4"	18"	18"	24 1/8"	24 1/8"
21" x 21"	21 3/4"	21 3/4"	21"	21"	27 1/8"	27 1/8"
24" x 24"	24 3/4"	24 3/4"	24"	24"	30 1/8"	30 1/8"

**NOTES:**

- ALL DOORS SUPPLIED WITH ADA COMPLIANT LOCKING LEVER HANDLE WITH TWO KEYS.
- ALL DOORS AVAILABLE LEFT OR RIGHT HINGED.

THESE DRAWINGS AND SPECIFICATIONS ARE THE PROPERTY OF CHUTES INTERNATIONAL AND SHALL NOT BE REPRODUCED OR COPIED OR USED AS THE BASIS FOR THE MANUFACTURE OR SALE OF APPARATUS WITHOUT PERMISSION. \*\*\*DO NOT DUPLICATE\*\*\*

DATE: 04/22/2013	Drawn By: HK
Revision: A	Approved By: HSS

**CHUTES**  
INTERNATIONAL  
MANUFACTURING

Phone: (301) 753-4100  
Toll Free: 800-88-CHUTE  
Fax: (301) 753-4109  
4400 Austin Lane  
White Plains, MD 20695  
WWW.CHUTES.COM

© 2013 CHUTES International

**Side Hinge Door – Typically Linen Chute Door**

## Appendix B

**NOTES:**

1. CUSTOMER TO PROVIDE MEASUREMENTS FOR CURB.
2. ROOF CAPS ALLOW VENTING UNDER NORMAL USE WITH HOLD DOWN CLIPS AND HINGES FOR MANUAL RELEASE FOR FULL VENTING IN CASE OF FIRE.
3. ROOF CAPS AND BASE FLASHING ARE 12GA. ALUMINUM SEALED WITH WEATHERPROOF CAULKING.
4. CURB AND ROOF CONSTRUCTED BY OTHERS.
5. VENT RISER SLIPS INSIDE FLASHING TO ALLOW FOR HEAT EXPANSION.

THESE DRAWINGS AND SPECIFICATIONS ARE THE PROPERTY OF CHUTES INTERNATIONAL AND SHALL NOT BE REPRODUCED OR COPIED OR USED AS THE BASIS FOR THE MANUFACTURE OR SALE OF APPARATUS WITHOUT PERMISSION. \*\*\*DO NOT DUPLICATE\*\*\*

**PITCHED ROOF FLASHING**

**PITCHED ROOF CURB**

**DETAIL "A"**

**FLAT ROOF FLASHING**

**FLAT ROOF CURB**

TYPICAL ROOF VENTS AND FLASHING CONFIGURATIONS	
DATE: 04/16/2013	Drawn By: HK
Revision: A	Approved By: HSS
	Phone: (301) 753-4100 Toll Free: 800-88-CHUTE Fax: (301) 753-4109 4400 Austin Lane White Plains, MD 20695 WWW.CHUTES.COM
© 2013 CHUTES International	

### Roof Vents and Flashing Configurations

## Appendix C

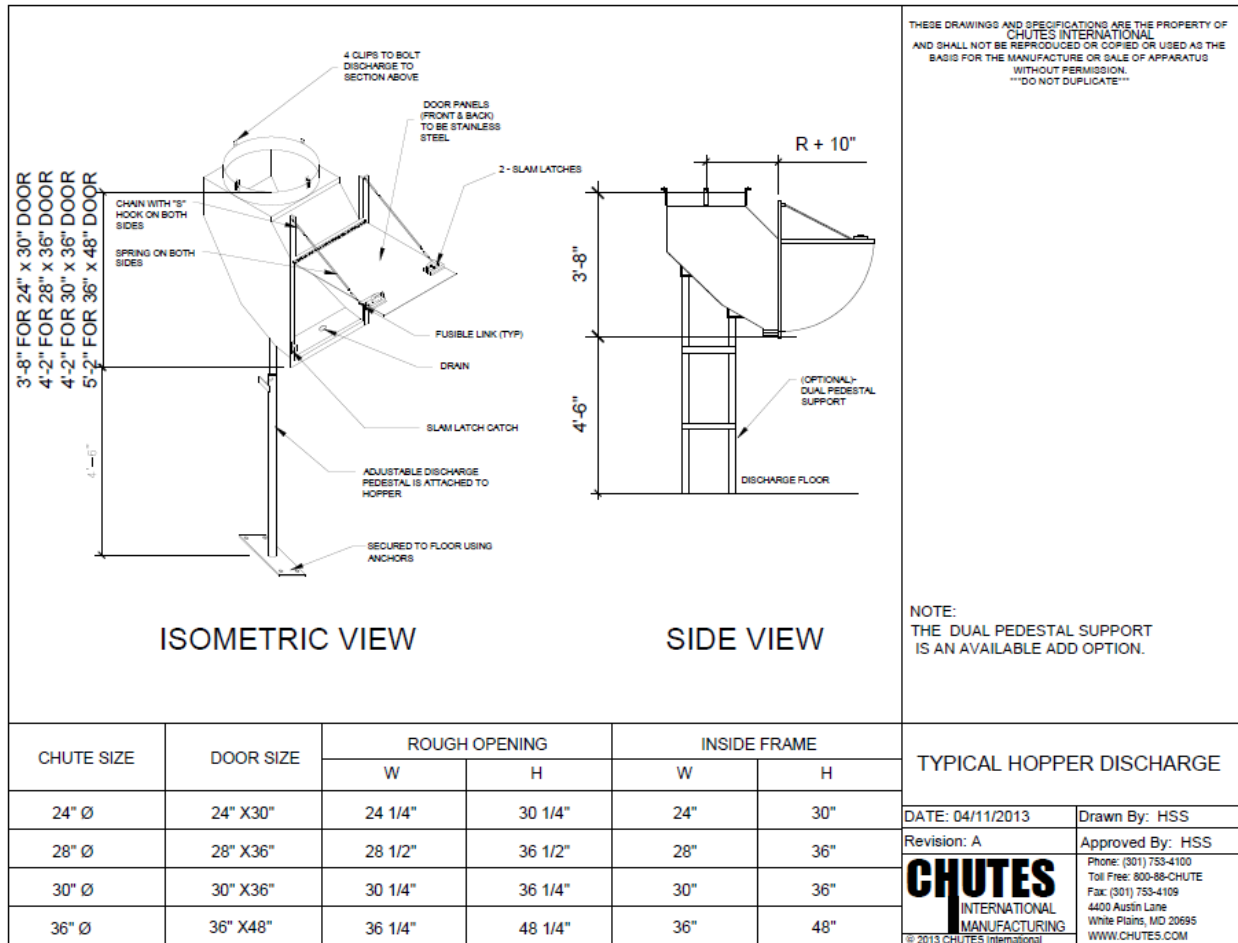

### Linen Chute Hopper Discharge

## Appendix D

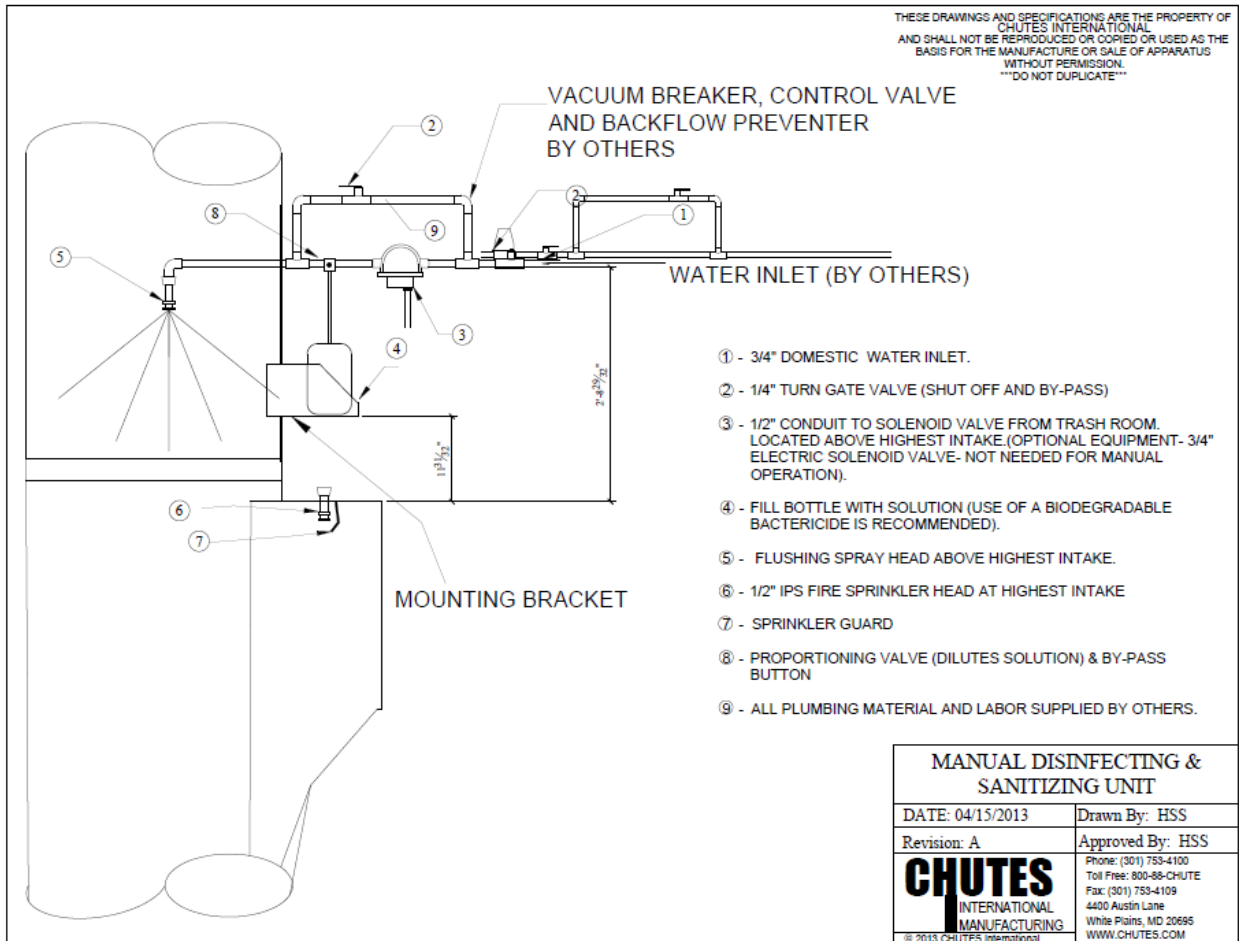

**Disinfecting & Sanitizing (D&S) Unit**

## Appendix E

THESE DRAWINGS AND SPECIFICATIONS ARE THE PROPERTY OF CHUTES INTERNATIONAL AND SHALL NOT BE REPRODUCED OR COPIED OR USED AS THE BASIS FOR THE MANUFACTURE OR SALE OF APPARATUS WITHOUT PERMISSION. "DO NOT DUPLICATE"

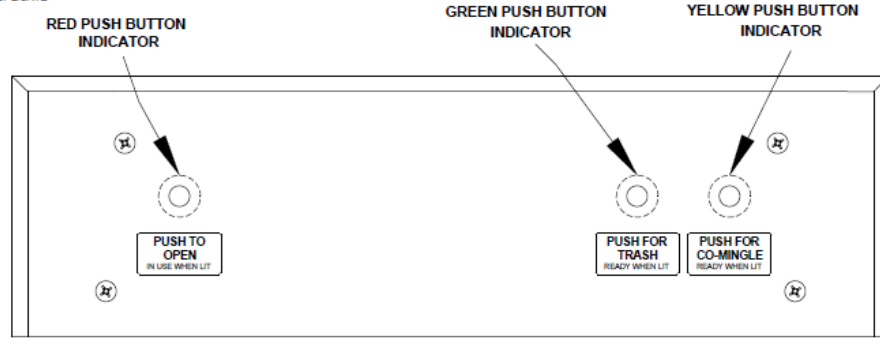

### BI-SORTER

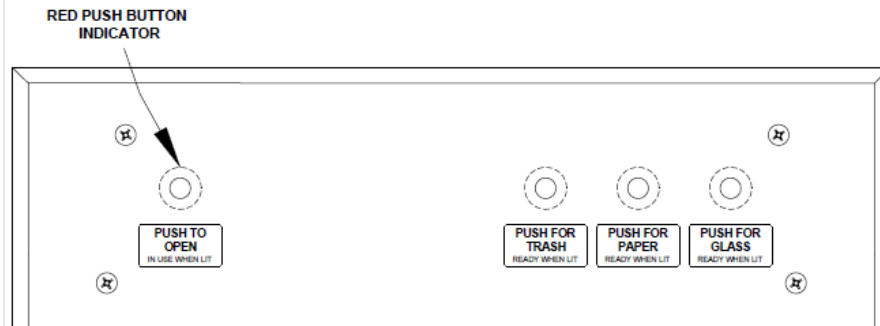

### TRI-SORTER

SORTER LABEL CONFIGURATION DETAIL APPENDIX "E"	
DATE: 07/07/2014	Drawn By: KF
Revision: A	Approved By: HSS
	Phone: (301) 753-4100 Toll Free: 800-88-CHUTE Fax: (301) 753-4109 4400 Austin Lane White Plains, MD 20696 WWW.CHUTES.COM
	© 2014 CHUTES International

### Label Configuration for Bi- and Tri-Sorter

## Appendix E

THESE DRAWINGS AND SPECIFICATIONS ARE THE PROPERTY OF CHUTES INTERNATIONAL AND SHALL NOT BE REPRODUCED OR COPIED OR USED AS THE BASIS FOR THE MANUFACTURE OR SALE OF APPARATUS WITHOUT PERMISSION. "DO NOT DUPLICATE"



**PNEUMATIC INTERLOCK**



**ELECTRIC INTERLOCK**

INTERLOCK LABEL CONFIGURATION DETAIL APPENDIX "E"	
DATE: 07/07/2014	Drawn By: KF
Revision: A	Approved By: HSS
<b>CHUTES</b> INTERNATIONAL MANUFACTURING	Phone: (301) 753-4100
	Toll Free: 800-88-CHUTE Fax: (301) 753-4109 4400 Austin Lane White Plains, MD 20695 WWW.CHUTES.COM
<small>© 2014 CHUTES International</small>	

### Label Configuration for Interlock Doors



## Appendix F

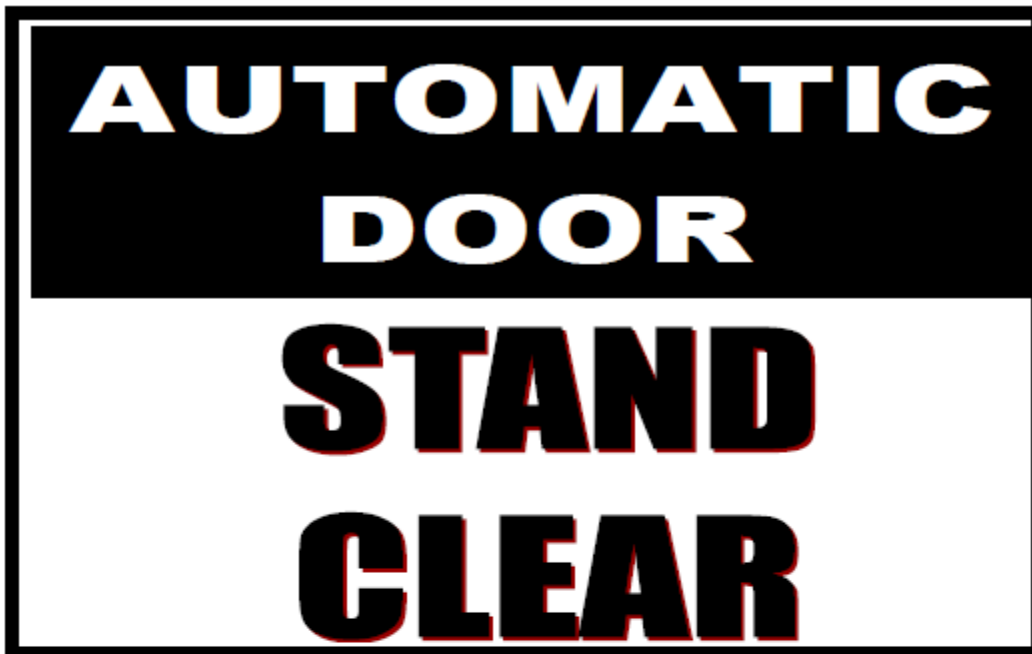

*Pneumatic Interlock Sign*



*Pneumatic Interlock Sign*